

### INSTRUCTION BOOKLET

Please read this instruction booklet before using the appliance

Keep this instruction book for future reference and ensure it is passed on to any new owner.

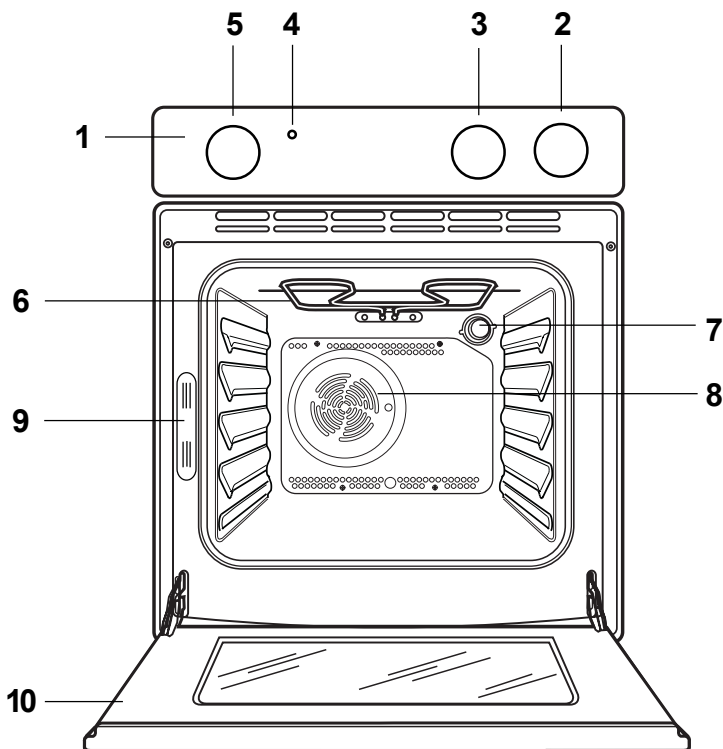

1. Control Panel
2. Thermostat Control Knob
3. Oven Function Control Knob
4. Thermostat Control Light
5. Minute minder

6. Grill
7. Oven light
8. Oven fan
9. Rating plate
10. Oven door



# Important Safety Information

You **MUST** read these warnings carefully before installing or using the oven. If you need assistance, contact our Customer Care Department on 08705 950950

## Installation

- This oven must be installed by qualified personnel to the relevant British Standards.
- This oven is heavy. Take care when moving it.
- Remove all packaging, both inside and outside the oven, before using the oven.
- Do not attempt to modify the oven in any way.

## Child Safety

- This oven is designed to be operated by adults. Do not allow children to play near or with the oven.
- The oven gets hot when it is in use. Children should be kept away until it has cooled.

## During Use

- This oven is intended for domestic cooking only. It is not designed for commercial or industrial purposes.
- Never line any part of the oven with aluminium foil.
- Do not allow heatproof cooking material, e.g. roasting bags, to come into contact with oven elements.
- Never place plastic or any other material which may melt in or on the oven.
- Do not place sealed cans or aerosols inside the oven. They may explode if they are heated.
- Do not hang towels, dishcloths or clothes from the oven or its handle.
- Do not use this oven if it is in contact with water and never operate it with wet hands.
- Take great care when heating fats and oils as they will ignite if they become too hot.
- Always use oven gloves to remove and replace food in the oven.
- Ensure that all control knobs are in the OFF position when not in use.
- Do not leave cookware containing foodstuffs, e.g. fat or oil in or on the oven in case it is inadvertently switched ON.

- When using other electrical appliances, ensure the cable does not come into contact with the hot surfaces of the oven.

## Maintenance and Cleaning

- Only clean this oven in accordance with the instructions.
- The oven should be kept clean at all times. A build-up of fats or other foodstuffs could result in a fire, especially in the grill pan.
- Always allow the oven to cool down and switch off the electrical supply before carrying out any cleaning or maintenance work.

## Service

- This oven should only be repaired or serviced by an authorised Service Engineer and only genuine approved spare parts should be used.

## Environmental Information

- After installation, please dispose of the packaging with due regard to safety and the environment.
- When disposing of an old appliance, make it unusable, by cutting off the cable. Remove any door catches, to prevent small children being trapped inside.

## Guide to Use the instructions

The following symbols will be found in the text to guide you throughout the Instructions:



Safety Instructions



Step by step instructions for an operation



Hints and Tips



Environmental information

# Controls

## Oven Function Control Knob



**Oven Light** - The oven light will be on without any cooking function.



**Defrost Setting** - This setting is intended to assist in thawing of frozen food.



**Fan Oven cooking** - This allows you to roast or roast and bake simultaneously using any shelf, without flavour transference.



**Grill** - The heat comes from the top element only.

## Thermostat Control Knob

Turn the thermostat control knob clockwise to select temperatures between 50°C and 250°C (MAX).

## Minute minder

The minute minder will mark the end of a timed period with an acoustic alarm. The maximum timing is 60 minutes.

Turn the minute minder knob to the maximum time position, then turn it back to the required time.

The minute minder will not affect in any way the oven operation, if it is in use.

## Thermostat Control Light

The thermostat control light will come on when the thermostat control knob is turned. The light will remain on until the correct temperature is reached. It will then cycle on and off to show the temperature is being maintained.

## The Safety Thermostat

This oven is provided with a safety thermostat. In case of malfunctioning of the main thermostat, and consequent over-heating, the safety device will stop the power supply to the appliance. If this happens, call your local Service Force Centre. Under no circumstances should you attempt to repair the appliance yourself.

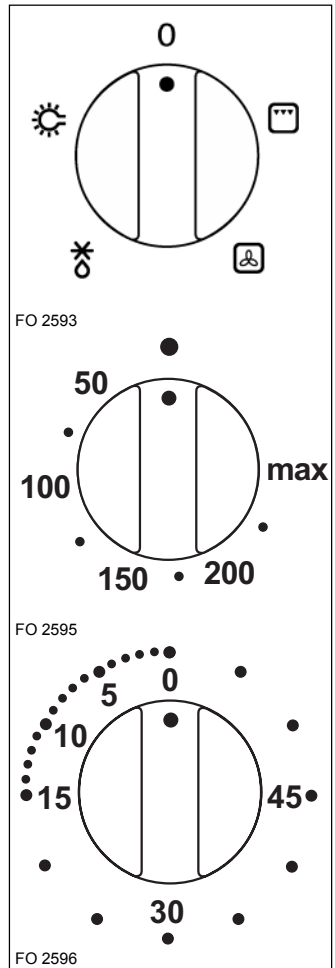



## Before the First Use



Remove **all packaging**, both inside and outside the oven, before using the appliance.

Before first use, the oven should be heated without food. During this time, an unpleasant odour may be emitted. This is quite normal.

 **1.** Switch the oven function control knob to fan cooking .

**2.** Set the thermostat control knob to MAX.

**3.** Open a window for ventilation.

**4.** Allow the oven to run empty for approximately 45 minutes.

This procedure should be repeated with the grill  function for approximately 5-10 minutes.

# Using the Oven



**Always cook with the oven door closed.**

Stand clear when opening the drop down oven door. **Do not** allow it to fall open - support the door using the door handle, until it is fully open.



The oven has four shelf levels, and is supplied with two shelves. The shelf positions are counted from the bottom of the oven as shown in the diagram.

Do not place cookware directly on the oven base.

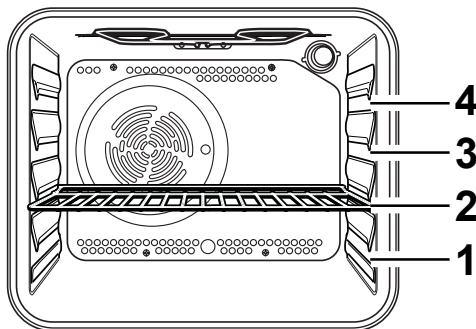

# Cleaning the Oven



**Before cleaning always allow the cooling fan to cool the cooker down before switching off at the electricity supply. Do not use steam cleaners.**

The oven should be kept clean at all times. A build-up of fats or other foodstuffs could result in a fire, especially in the grill pan.

Before using any cleaning materials on your oven, check that they are suitable and that their use is recommended by the manufacturer.

Cleaners that contain bleach and harsh abrasives should **NOT** be used.

For external and internal cleaning, use a soft cloth well wrung out in warm water to which a little liquid detergent has been added.

To prevent damaging or weakening the door glass panels avoid the use of the following: household detergent and bleaches, impregnated pads unsuitable for non-stick saucepans, "Brillo/Ajax" pads or steel wool pads, chemical oven pads or aerosols, rust removers, bath/sink stain removers. Should the inner door glass become heavily soiled it is recommended that a cleaning product such as Hob Brite is used.

**DO NOT clean the oven door while the glass panels are warm. If this precaution is not observed the glass panel may shatter.**



If the door glass panel becomes chipped or has deep scratches, it must be replaced to prevent the possibility of the panel shattering. Contact your local Service Force Centre.

# Cooking Chart

The oven temperatures are intended as a guide only. It may be necessary to increase or decrease the temperatures by 10 °C to suit individual preferences and requirements.

**NOTE: Shelf positions are counted from bottom of the oven.**

Food	Cooking Temp (°C)	Shelf Position
Biscuits	180-190	Shelf positions are not critical but ensure that oven shelves are evenly spaced when more than one is used.
Bread	210-220	
Casseroles	130-140	
Cakes:		
- Small and queen	160-170	
- Sponges	160-170	
- Madeira	140-150	
- Rich Fruit	130-140	
- Christmas	130-140	
- Meringues	90-100	
Fish	170-190	
Fruit Pies and Crumbles	190-200	
Milk Puddings	130-140	
Pastry:		
- Choux	190-200	
- Shortcrust		
- Flaky		
- Puff		
Plate Tarts	180	
Quiches/Flans	170-180	
Scones	210-220	
Roasting:		
- Meat & Poultry	160-280	

## Grilling Chart

Cooking time depends on the thickness of the meat and not on its weight.



**Grilling must be carried out with the oven door closed. The grill pan handle must be removed from the pan.**

Type of food	Mins perside
Bacon rashers	2 - 5
Chicken joints	15 - 20
Gammon rashers	5 - 8
Lamb chops	6 - 12
Pork chops	10 - 15
Sausages (turning as required)	10 - 12
Steaks (average thickness)	
Rare	3 - 6
Medium	6 - 10
Well done	8 - 12
Toast	1 - 1½

## Replacing The Oven Light



### Disconnect the appliance

If the oven bulb needs replacing, it must comply with the following specifications:

Electric power: 15W; Electric rate: 230-240V (50 Hz); Resistant to temperatures of 300°C; Connection type: E14.

These bulbs are available from your local Service Force Centre. To replace the faulty bulb:

1. Ensure the oven is isolated from the electrical supply.
2. Turn the glass cover counterclockwise.
3. Remove the faulty bulb and replace with the new one.
4. Refit the glass cover and restore the electrical supply.

## Something not working

If the appliance is not working correctly, please carry out the following checks, before contacting your local Service Force Centre.

**IMPORTANT:** If you call out an engineer to a fault listed below, or to repair a fault caused by incorrect use or installation, a charge will be made even if the appliance is under guarantee.

SYMPTOM	SOLUTION
<ul style="list-style-type: none"> <li>■ The oven does not come on</li> </ul>	<ul style="list-style-type: none"> <li>◆ Check that both a cooking function and temperature have been selected.</li> <li>◆ Check the appliance is wired in properly, and the socket switch or the switch from the mains supply to the oven are ON.</li> </ul>
<ul style="list-style-type: none"> <li>■ The oven temperature light does not come on</li> </ul>	<ul style="list-style-type: none"> <li>◆ Select a temperature with the thermostat control knob</li> <li>◆ Select a function with the oven function control knob.</li> </ul>
<ul style="list-style-type: none"> <li>■ The oven light does not come on</li> </ul>	<ul style="list-style-type: none"> <li>◆ Select a function with the oven function control knob</li> <li>◆ Check the light bulb, and replace it if necessary (see above)</li> </ul>
<ul style="list-style-type: none"> <li>■ It takes too much time to finish the dishes, or they are cooked too fast.</li> </ul>	<ul style="list-style-type: none"> <li>◆ The temperature may need adjusting</li> <li>◆ Refer to the contents of this booklet, especially to the chapter "Using the Oven".</li> </ul>
<ul style="list-style-type: none"> <li>■ Steam and condensation settle on the food and the oven cavity.</li> </ul>	<ul style="list-style-type: none"> <li>◆ Leave dishes inside the oven no longer than 15-20 minutes after the cooking is completed.</li> </ul>

# Service and Spare Parts

## **SERVICE FORCE**

If you require spare parts or an engineer contact your local Service Force Centre by telephoning:

**08705 929 929**

Your call will be routed to the Service Centre covering your post code area. The addresses of Service Force Centres are detailed on the following pages.

### **CUSTOMER CARE**

For general enquiries concerning your Moffat appliance and for further information on Moffat products, contact our Customer Care Department by letter or telephone as follows:

#### **Customer Care Department Moffat**

55-77 High Street  
Slough  
Berkshire SL1 1DZ  
Tel : 08705 950950

\* calls to this number may be recorded for training purposes

## **Guarantee Conditions**

We, Moffat, undertake that if, within 12 months of the date of the purchase, this Moffat appliance or any part thereof is proved to be defective by any reason only of faulty workmanship or materials, we will, at our option, repair or replace the same **FREE OF ANY CHARGE** for labour, materials or carriage on condition that:

- \* The appliance has been correctly installed and used only on the gas and electricity supply stated on the rating plate.
- \* The appliance has been used for normal domestic purposes only, and in accordance with the manufacturer's instructions.
- \* The appliance has not been serviced, maintained, repaired, taken apart or tampered with by any person not authorised by us.
- \* All service work under this guarantee must be undertaken by a Moffat Service Force Centre.
- \* Any appliance or defective part replaced shall become the Company's property.
- \* This guarantee is in addition to your statutory and other legal rights.

Home visits are made between **8.30am and 5.30pm** Monday to Friday. Visits may be available outside these hours, in which case a **premium** will be charged.

#### **Exclusions**

**This guarantee does not cover:**

- \* Damage or calls resulting from transportation, improper use or neglect, the replacement of any light bulbs or removable parts of glass or plastic.
- \* Costs incurred for calls to put right an appliance which is improperly installed or calls to appliance outside the United Kingdom.
- \* Appliances found to be in use within a commercial or similar environment, plus those which are the subject to rental agreements.
- \* Products of Moffat manufacture which are not marketed by Moffat.

#### **European Guarantee**

If you should move to another country within Europe then your guarantee moves with you to your new home subject to the following qualifications:

- \* The guarantee starts from the date you first purchased your product.
  - \* The guarantee is for the same period and to the same extent for labour and parts as exist in the new country of use for this brand or range of products.
  - \* This guarantee relates to you and cannot be transferred to another user.
  - \* Your new home is within the European Community (EC) or European Free Trade Area.
  - \* The product is installed and used in accordance with our instructions and is only used domestically, i.e. a normal household
- The electrical supply complies with the specification given in the rating label.
- \* The product is installed taking into account regulations in your new country.

Before you move, please contact your nearest Customer Care centre, listed below, to give them details of your new home. They will then ensure that the local Service Organisation is aware of your move and able to look after you and your appliances.

France	Senlis	+33 (0) 3 44 62 20 13
Germany	Nürnberg	+49 (0) 800 234 7378
Italy	Pordenone	+39 (0) 800117511
Sweden	Stockholm	+46 (0) 20 78 77 50
UK	Slough	+44 (0) 1753 219898

# Technical Data

## Heating element ratings

Fan cooking element	2,080 W
Grill element	1,830 W
Oven Fan	25 W
Oven Light	15 W
Cooling Fan	20 W
Total Rating	2,150 W

## Dimensions of the oven cavity

Height	325 mm.
Width	440 mm.
Depth	400 mm.
Oven capacity:	55 litres

1	Manufacturer	Moffat
2	Model	MSF 610
3	Energy efficiency class	
4	- Conventional	
5	- Forced air convection	
	Energy consumption Heating function:	
6	- Conventional	0,79 kW/h
7	- Forced air convection	0,78 kW/h
8	- Steam	
9	Usable volume (litres)	53,0
	Size: - Small - Medium - Large	
	Time to cook standard load:	
10	- Conventional	43 min.
11	- Forced air convection	41 min.
12	The area of the largest baking sheet	1130 cm <sup>2</sup>
13	Noise (dB (A) re 1 pW)	
<p>More efficient <span style="float: right;">Less efficient</span></p> <p>●● 12 l ≤ Usable volume &lt; 35 l          ●●● 35 l ≤ Usable volume &lt; 65 l          ●●●● 65 l ≤ Usable volume</p>		
2002/40/EC		



This appliance complies with the following **E.E.C.**

### Directives:

- **73/23 - 90/683** (Low Voltage Directives)
- **93/68** (General Directive);
- **89/336** (Electromagnetical Compatibility Directive) and subsequent modifications.

# Electrical Connection

The oven is designed to be connected to 230-240V (50Hz) electricity supply.

The oven has an easily accessible terminal block which is marked as follows:

Letter L	-	Live terminal
Letter N	-	Neutral terminal
or E	-	Earth terminal



## THIS OVEN MUST BE EARTHED

The cable used to connect the oven to the electrical supply must comply to the specifications given below.

It is necessary that you install a double pole

Connection via	Min. size Cable/flex	Cable / flex type	Fuse
13 A socket outlet	2.5 mm <sup>2</sup>	3 core butyl insulated	13 A min.
13 A spur box			
Cooker Control Circuit	2.5 mm <sup>2</sup>	PVC/PVC twin and earth	13 A

switch between the oven and the electricity supply (mains), with a minimum gap of 3mm between the switch contacts and of a type suitable for the required load in compliance with the current rules.

The switch must not break the yellow and green earth cable at any point.

### Important

After installation and connecting, the cable must be placed so that it cannot at any point reach a temperature of more than 60°C above the ambient temperature.

Before the oven is connected, check that the main fuse and the domestic installation can support the load and that the power supply is properly earthed.

**The manufacturer declines any responsibility should these safety measures not be carried out.**

# Building In

Please ensure that when the oven is installed it is easily accessible for the engineer in the event of a breakdown.

The surround or cabinet into which the oven will be built must comply with these specifications:

- the dimensions must be as shown in the relevant diagrams;
- the materials must withstand a temperature increase of at least 60°C the above temperature;
- proper arrangements must be made for a continuous supply of air to the oven to prevent the oven overheating.

Dimensions of the oven and recess required are given in the relevant diagrams.

## Securing The Oven To The Cabinet

1. Fit the oven into the cabinet recess,
2. Open the oven door
3. Secure the oven to the kitchen cabinet with four wood screws, which fit the holes provided in the oven frame.

